



JOHN MAST A/S  
Lunikvej 12  
DK - 2670 Greve  
Denmark

Tel.: +45 - 43 90 56 00  
Fax: +45 - 43 90 00 60  
mail@johnmast.com  
www.johnmast.com

# 103D

REF: 103D - Kundetegning-Default

Revision

-

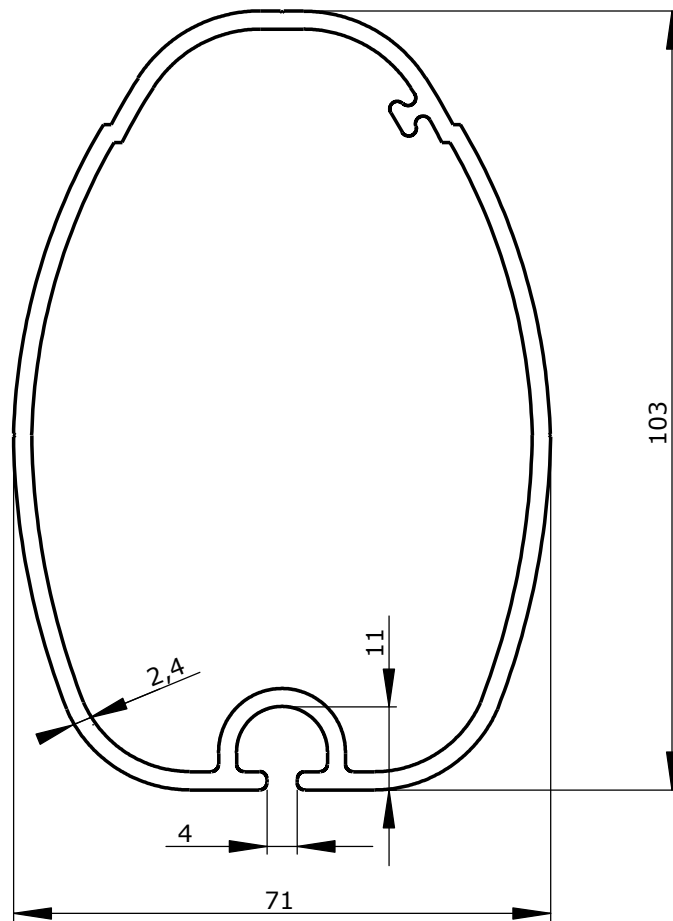

Scale: 1:1

Vægt = 2.0 kg/m  
 $I_x = 45 \text{ cm}^4$   
 $I_y = 93 \text{ cm}^4$